

Optimisation of Ca/Zn Stabiliser System in Clear Rigid PVC – Selection of Impact Modifiers

Stefan Scholz, CATENA Additives



16th February 2011

Content

- Introduction
 - Who we are
 - Today's Focus: Optimisation of a Ca/Zn system in clear rigid PVC
- Investigations Performed and Results
- Conclusion

Introduction

FLORIDIENNE Group: Supplier of Plastic Additives



IKA

CATENA
Additives

- Pipes
- Cable

- Window profile
- Sheets

- P-PVC
- FR



Core Product Lines

PVC-Stabilisers



Flame Retardants



® Reg. Trademarks of CATENA Additives

Main Issues for Composing a PVC Compound

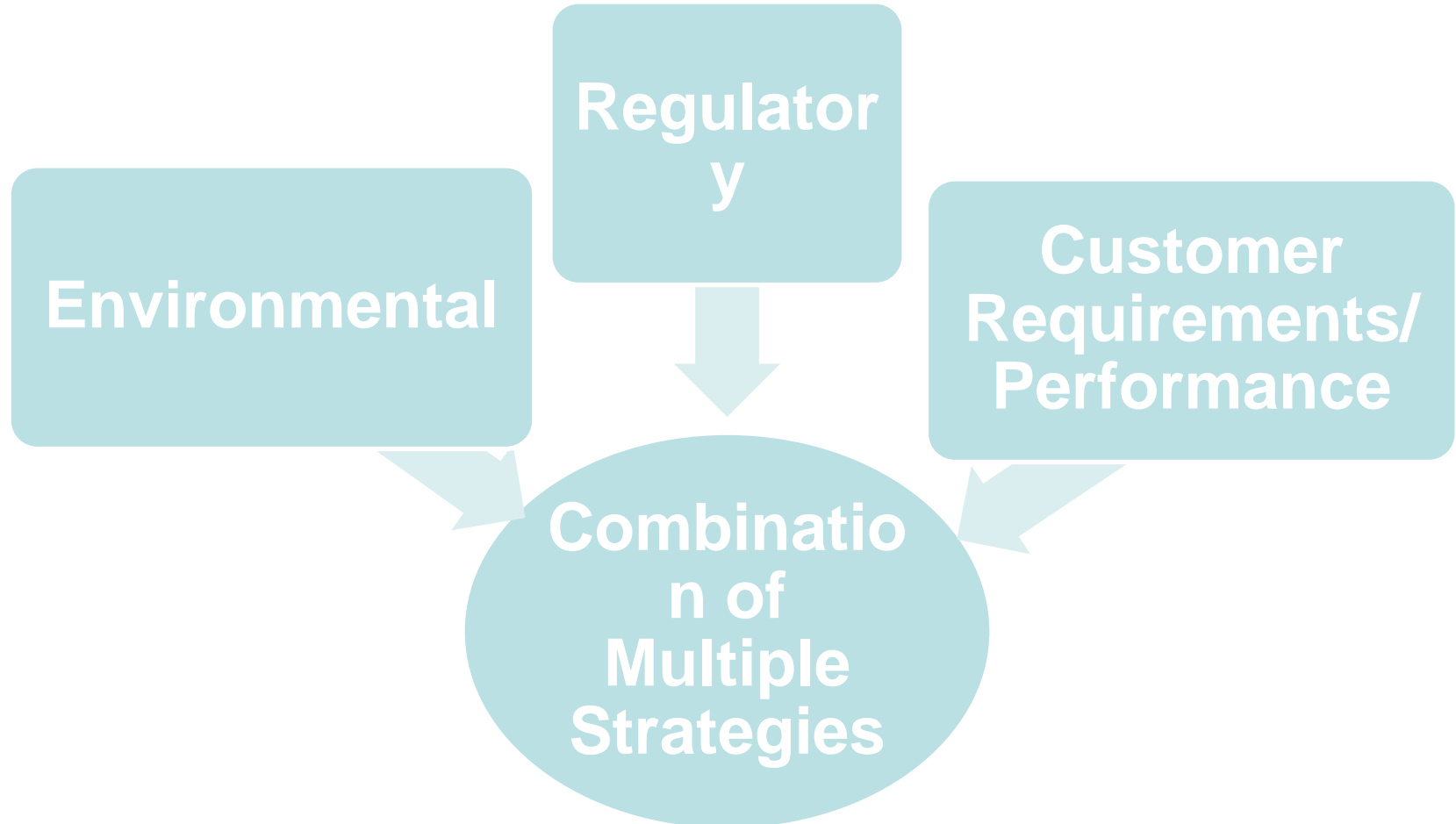

Today's Focus:



- EuroStab[®] XT 21HS and its applicability in rigid transparent applications under consideration of
 - Transparency
 - Light stability
 - Impact properties

Transparency in Rigid Clear PVC

Production scale samples



Sn-Reference

**EuroStab[®] XT 21HS-
system**

Artificial Weathering in Rigid Clear PVC

QUV-Test: UV-A (340 nm), Radiation 60 C/ 4 h, Thawing 45 C/ 4 h

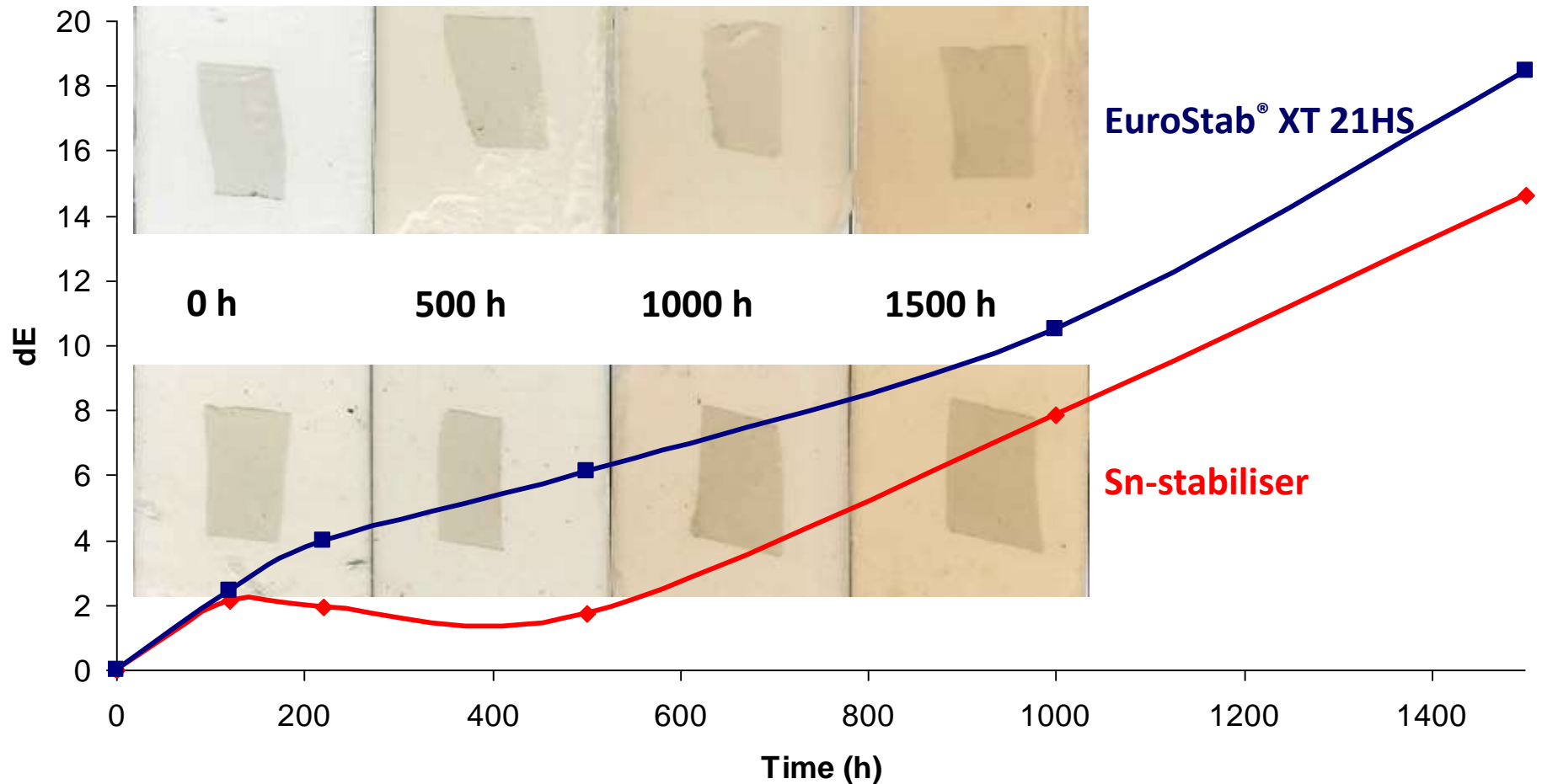

Motivation of the Study

- During the development phase several observations were made related to interactions between stabiliser system and other processing additives like lubricants and impact modifiers
- A systematic study was done to find out solutions to overcome this

Suitable Impact Modifiers for Clear Applications

- MABS: Methacrylate-acrylonitrile-butadiene-styrene
- MBS: Methacrylate-butadiene-styrene
- Two suitable MBS types were selected based on prior investigations

MBS Impact Modifier: **CATENA** Additives

Core Shell Structure

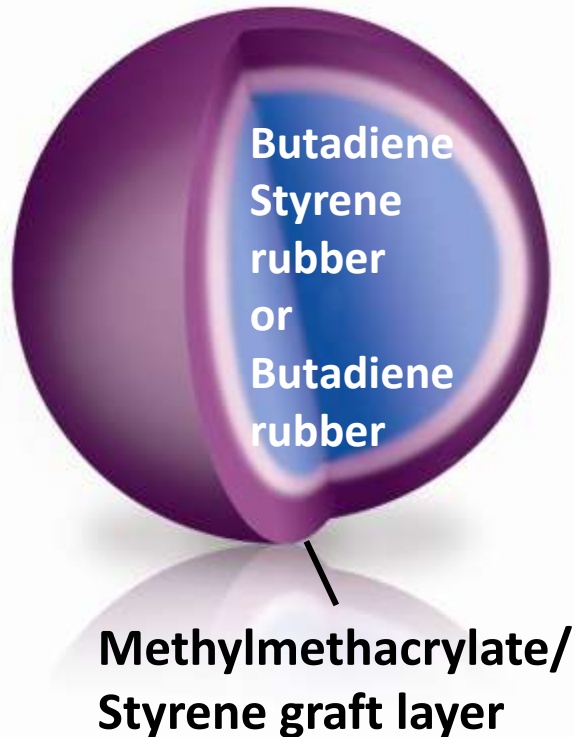

- Rubber core for energy absorption
- Grafted layer for compatibility with PVC phase
- Styrene content for transparency
- Chosen for investigations :
 - Kane ACE B 580
(high quality standard type)
 - Kane ACE B 382
(oil resistant type)

Basic Formulation

- PVC (K = 60) 100 parts
- Lubricants 1.1 parts
- Processing Aids 0.6 parts
- Kane ACE B 382 or Kane ACE B 580 6 to 10 parts
- EuroStab® XT 21HS stabiliser system 6 parts
- Sn-reference 2 parts
- Test samples: milled sheet, pressed sheet and extruded rods

Static Heat Stability:

with Kane ACE B 580 (8.0 parts)

Sheets milled at 195 C/ 5 Min.

Metrastat at 200 C

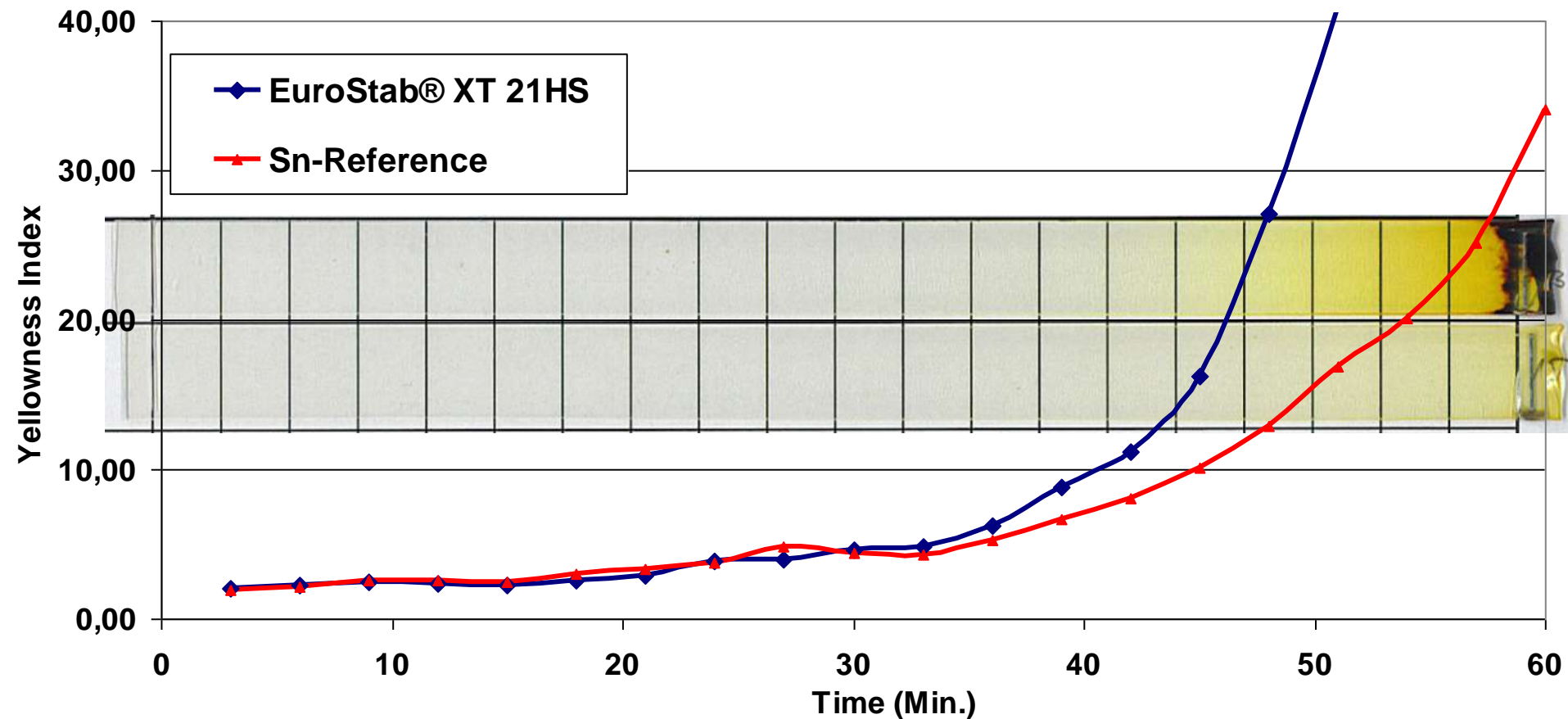

Static Heat Stability:

with Kane ACE B 382 8.0 parts

Sheets milled at 195 °C / 5 Min., Metrastat at 200 °C

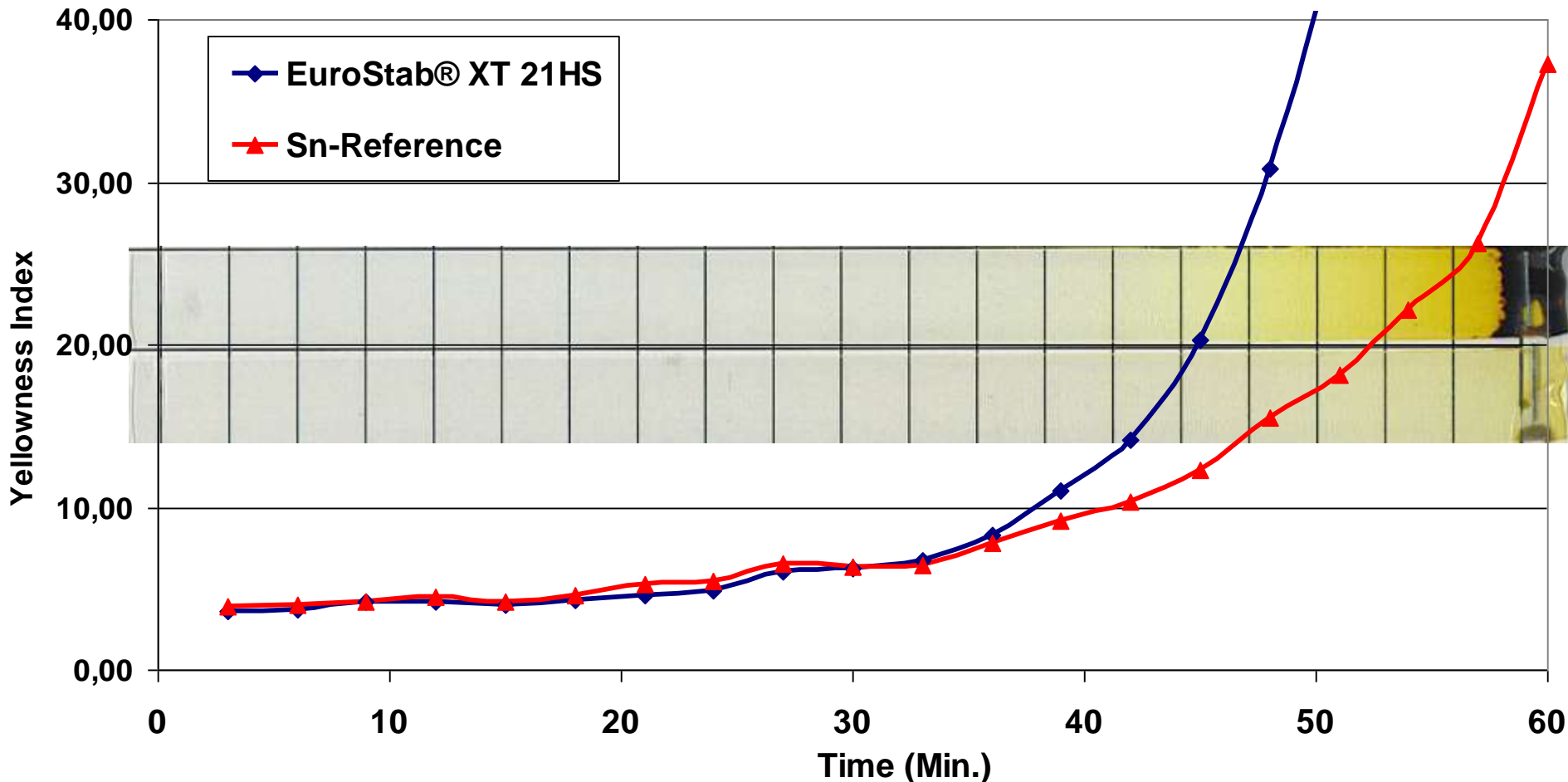

Static Heat Stability:



Effect of Load of Impact Modifier

EuroStab® XT 21HS, Kane ACE B 580 (0 phr to 10 phr)

Sheets milled at 195 C/ 5 Min., Metrastat at 200 C

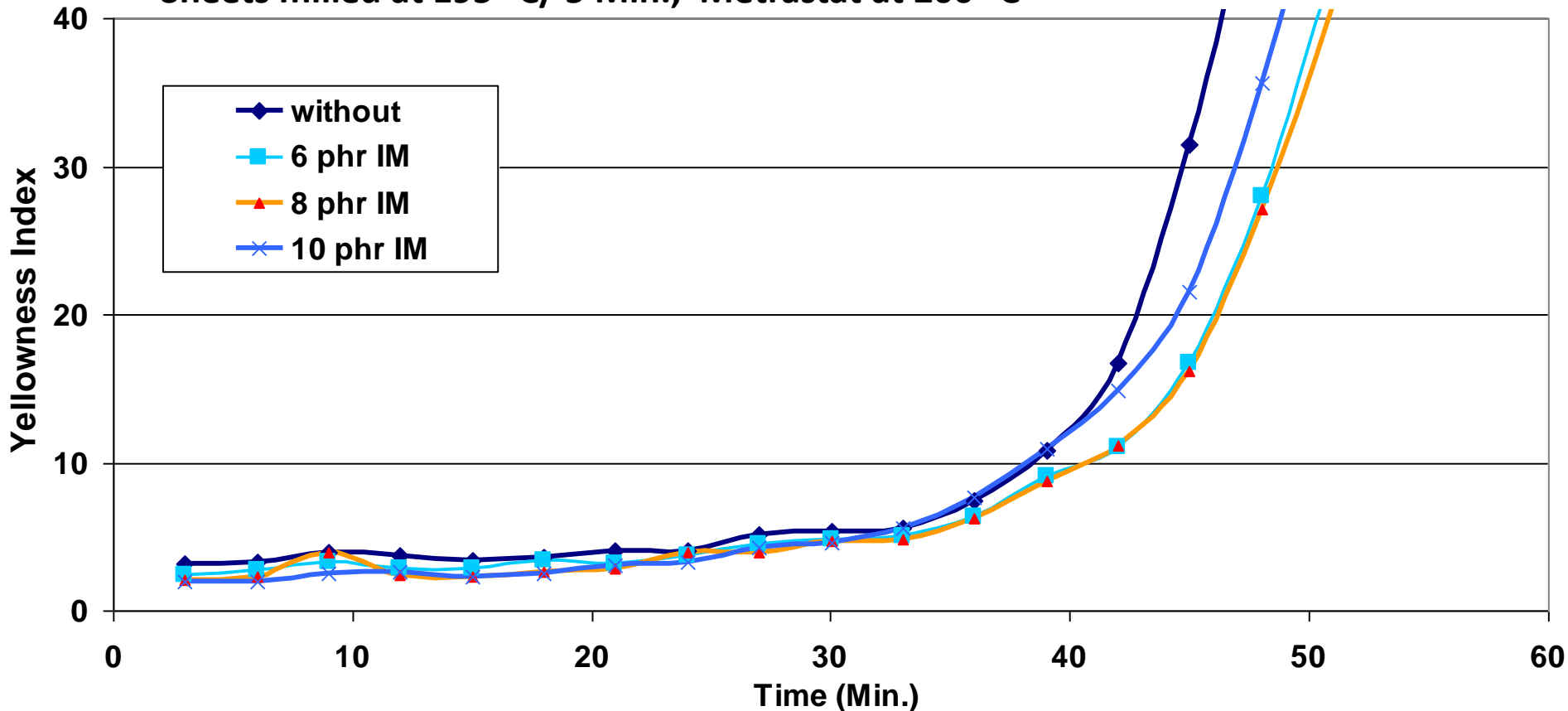

Dynamic Stability in Rigid Clear PVC

Two roll mill test, 195 C

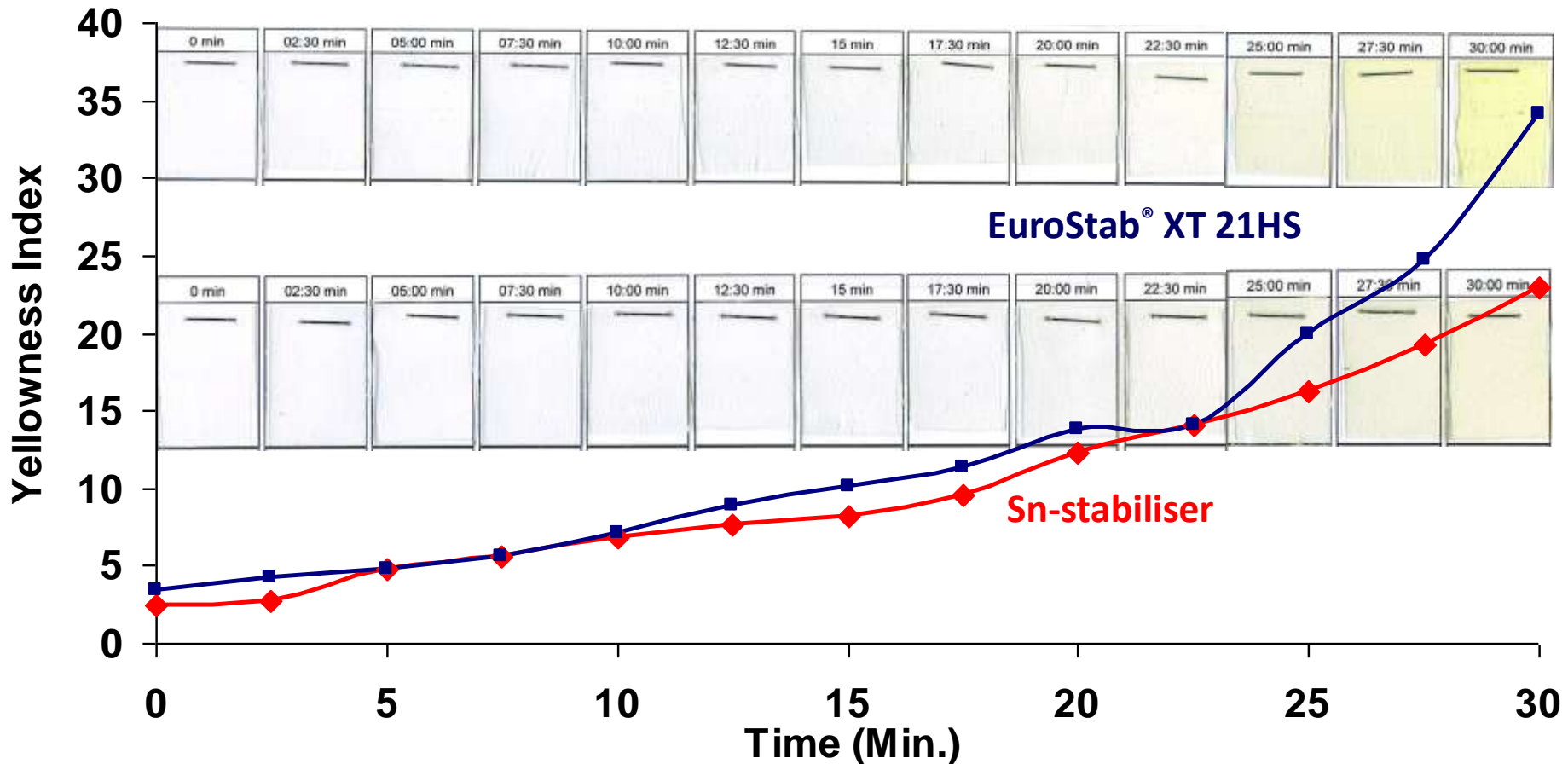

Mechanical Properties: **CATENA** Additives

IZOD Impact Strength

Measurement according to ASTM D256 (23 °C)

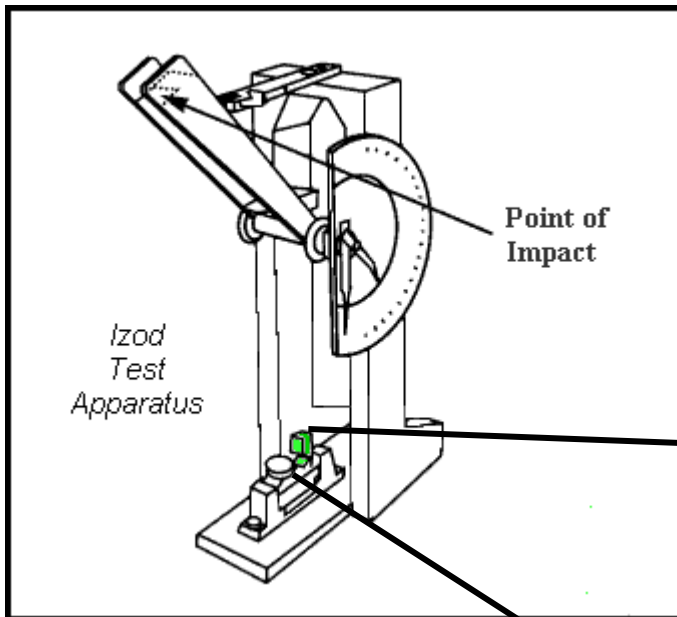

- Notched sample
- Made out of pressed sheets
- Pendulum swings and breaks specimen
- Energy passed to sample is measured

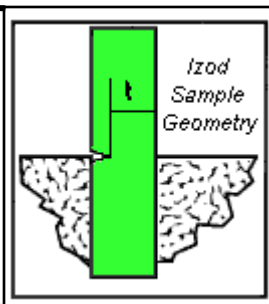

Source: matweb.com

Mechanical Properties:

IZOD Impact Strength

Measurement according to ASTM D256 (23 °C)

[kg · cm/cm ²]	Sn-Reference	EuroStab[®] XT 21HS-system
Without IM	4.4 (± 0.5)	4.2 (± 0)
Kane ACE B 382	9.5 (± 0.5)	8.8 (± 0.5)
Kane ACE B 580	11.5 (± 0)	10.3 (± 1.0)

Oil Stress Test

- Oil stress test describes resistance of specimen towards oil, especially edible oils
- A test sample – extruded rod – is placed in oil bath for up to 80 min. under mechanical stress
- Change of impact properties is detected

Oil Stress Test: Procedure

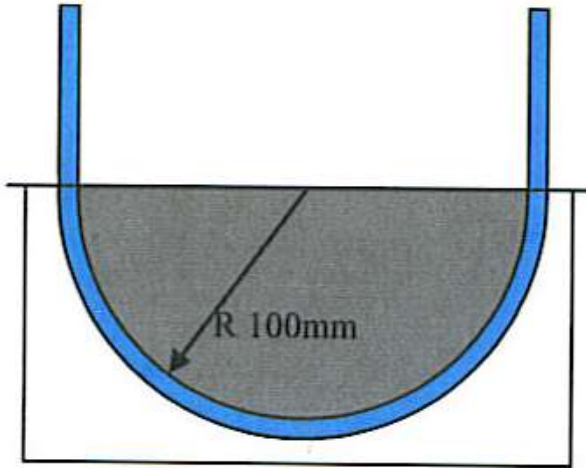

- Extruded rods
- Bended around pipe
- Stored in oil for 10 minutes to 80 minutes
- Pieces tested with IZOD pendulum
- Number of surviving rods noted

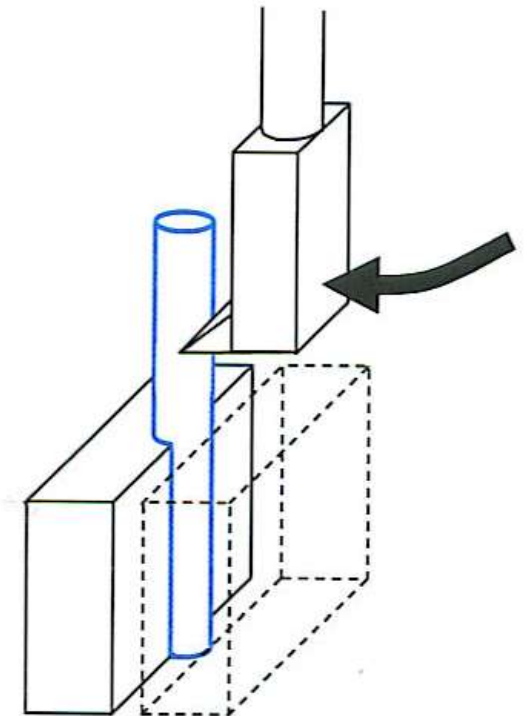

Oil Stress Test: Results

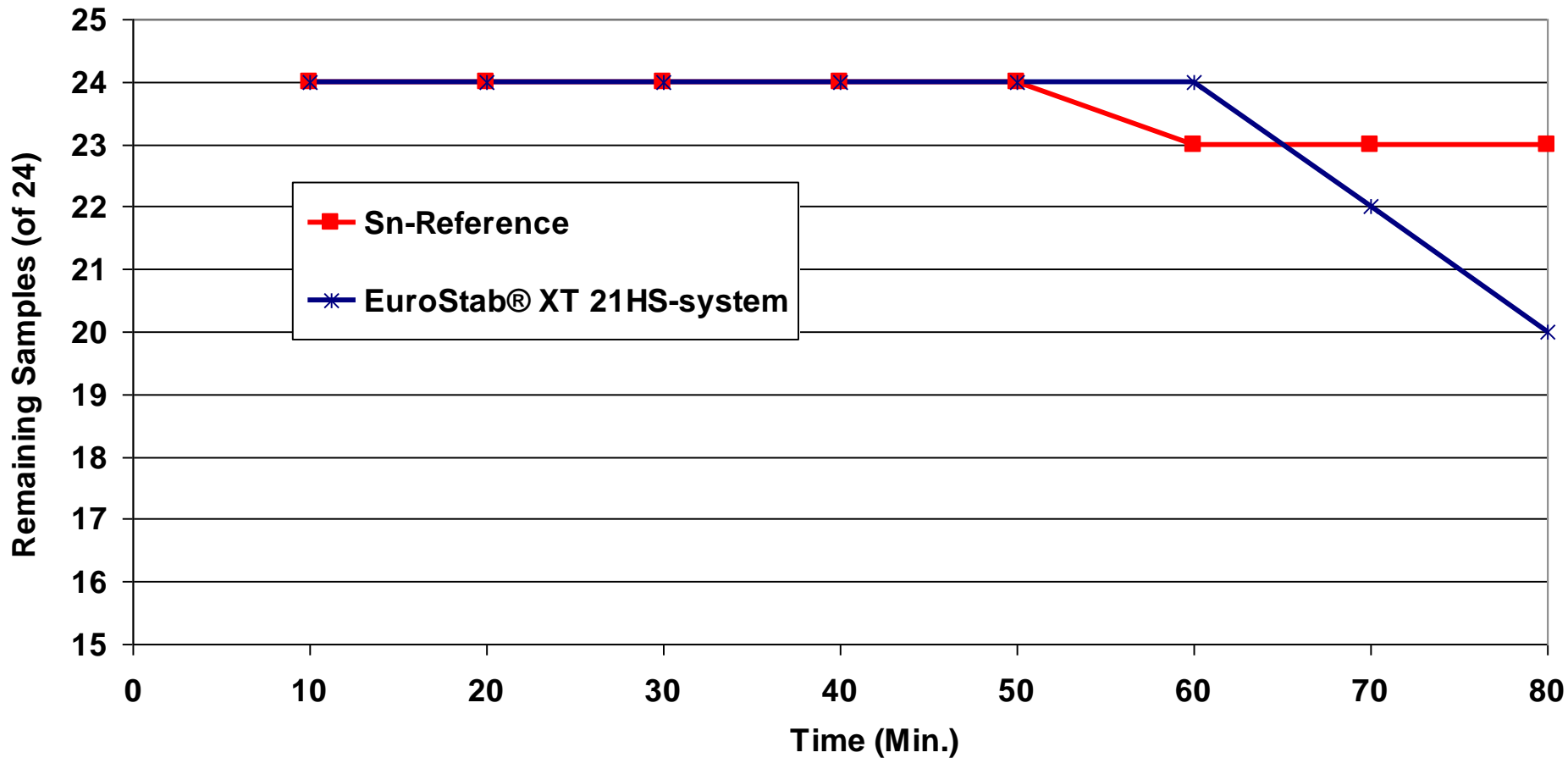

Results and Discussion

Results and Discussion

- Static Heat Test
 - EuroStab[®] XT 21HS close to Sn-stabiliser
 - Both Impact Modifiers do not show negative effect on performance

Results and Discussion

- IZOD Impact Strength
 - EuroStab[®] XT 21HS together with Impact Modifier show comparable impact strength to Sn-stabiliser
- Oil Stress Test
 - EuroStab[®] XT 21HS meets Sn-Reference behaviour

Conclusion

EuroStab[®] XT 21HS

- Recommended for rigid clear applications
- For in- and outdoor use; e.g. corrugated sheets
- Replacement for Tin-based stabilisers

Acknowledgement

- Thanks to
Kaneka Belgium N. V.
for kind support

The logo for KANeka, featuring the word "KANeka" in a bold, blue, sans-serif font with a stylized "K" and "A".

Thank You!